

未注公差/General tolerances(mm)													0.1/10 ±2'
0 ~ 3	>3 ~ 6	>6 ~ 10	>10 ~ 18	>18 ~ 30	>30 ~ 50	>50 ~ 80	>80 ~ 120	>120 ~ 180	>180 ~ 250	>250 ~ 315	>315 ~ 400	>400 ~ 500	
±0.12	±0.18	±0.22	±0.26	±0.31	±0.37	±0.57	±0.80	±0.93	±1.05	±1.15	±1.60	±2.20	±2.50

A

B

C

D

A

B

C

D

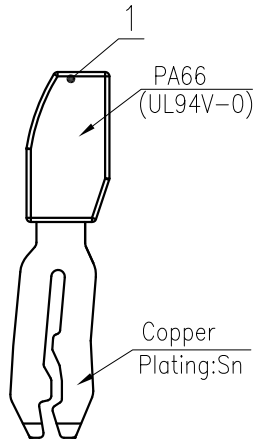
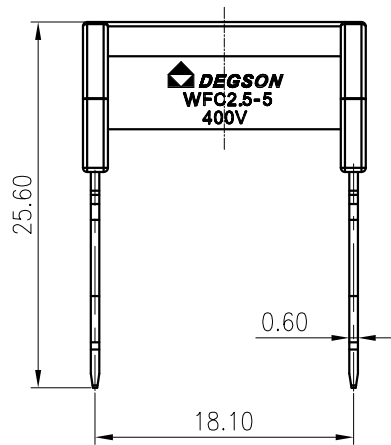
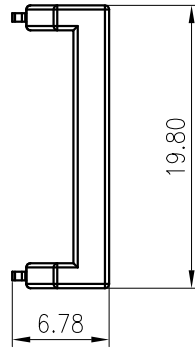

1	WFC2.5-5-01P-1Y-00A(H)		
ITEM	NAME OF PART	MATERIAL	NOTES
间距/Pitch(mm)/线数范围/Poles		18.10/01P	
使用温度范围/Operating temperature(°C)		-40~+105	
符合RoHS环保要求/Conform to RoHS		Yes	

MATERIAL:		SURFACE:	
MAT NO.:	/	宁波高松电子有限公司 NINGBO DEGSON ELECTRICAL CO., LTD	
STATUS:	/		
APPD:	Li GL 2020.06.06	NAME:	
CHKD:	Mao J 2020.06.06	WFC2.5-5-01P-1Y-00A(H)	
DRFT:	Feng X 2020.05.26	DRAWING NO.:	WFC2.5-5-C01
REV	ECN	REV	TO
DESCRIPTION	DRFT	DATE	TO
SIZE: A4	mm (inch)	TYPE: CUSTOMER DRAWING	SCALE: 2:1 SHEET 1/1

REV	ECN	DESCRIPTION	DRFT	DATE
-----	-----	-------------	------	------