

未注公差/General tolerances(mm)												0.1/10	
0	>3	>6	>10	>18	>30	>50	>80	>120	>180	>250	>315		>400
~3	~6	~10	~18	~30	~50	~80	~120	~180	~250	~315	~400	~500	~2.50
±0.12	±0.18	±0.22	±0.26	±0.31	±0.37	±0.57	±0.80	±0.93	±1.05	±1.15	±1.60	±2.20	±2.50

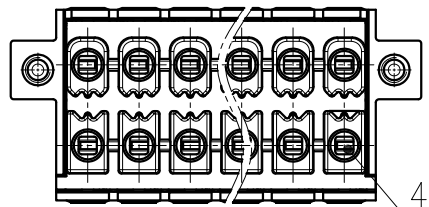
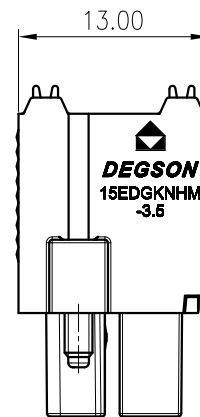
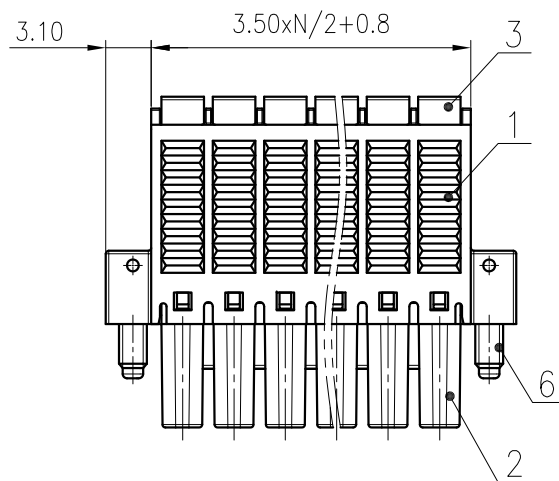
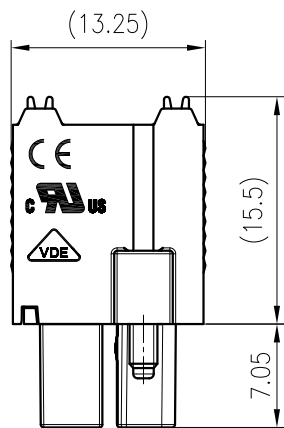
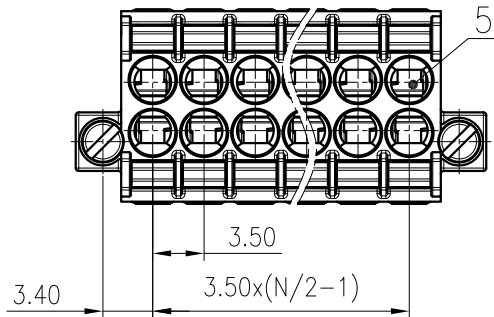

6	Screw	Steel	M2/Zn Plated
5	Spring	Stainless steel	
4	Clamp	Copper alloy	Sn Plated
3	Button	POM	UL94HB
2	Cover	PA66	UL94V-0
1	Housing	PA66	UL94V-0

ITEM	NAME OF PART	MATERIAL	NOTES
UL 标准/UL Standard:		B	C
额定电压/电流/Rated Voltage(V)/Current(A)		300/8	50/8
IEC 标准/IEC Standard:			
过压类别/Overvoltage Category/污染等级/Pollution Degree		III/3	III/2
额定电压/电流/Rated Voltage(V)/Current(A)		200/9.5	250/9.5
额定脉冲电压(KV)/Rate Impulse Voltage(KV)		2.5	2.5
线径范围(硬线和软线)/Wire Range(rigid and flexible)(AWG/mm ²)		26~16/0.2~1.5	
间距/Pitch(mm)/线数范围/Poles		3.50/N=04~48P	
剥线长度/Stripping length(mm)		10	
使用温度范围/Operating temperature(°C)		-40~+105	
符合RoHS环保要求/Conform to RoHS		Yes	

MATERIAL:		SURFACE:	
MAT NO.:		宁波高松电子有限公司 NINGBO DEGSON ELECTRICAL CO., LTD	
STATUS:	/		
APPD:	Lan ChH 2021.11.03	NAME:	
CHKD:	/	15EDGKNHM-3.5-XXP-1Y-00A(H)	
DRFT:	Yu JZh 2021.11.03	DRAWING NO.: 15EDGKNHM-3.5-C01	
REV	ECN	DESCRIPTION	DRFT
SIZE: A4	mm (inch)	TYPE: CUSTOMER DRAWING	SCALE: 2:1
		SHEET	1/1

Transfer or duplication of this document as well as the utilization or communication of its contents are prohibited unless explicit authorization is granted. Violations will be liable for compensation. All rights reserved for patent, utility, model or designs registrations. 除非给予明确授权，否则禁止转让、复制、利用、交流本文件的内容。未经许可擅自涉及及发明，实用新型和外观设计的所有权利。