

精度等级/General Tolerances(mm)		尺寸/Dimension												
0	>3	>6	>10	>18	>30	>50	>80	>120	>180	>280	>315	>400	>500	0.1/1/10
~	~	~	~	~	~	~	~	~	~	~	~	~	~	±Z
3	6	10	18	30	50	80	120	180	280	315	400	500	>500	±Z
±0.12	±0.18	±0.22	±0.26	±0.31	±0.37	±0.57	±0.80	±0.93	±1.05	±1.15	±1.60	±2.20	±2.50	±Z

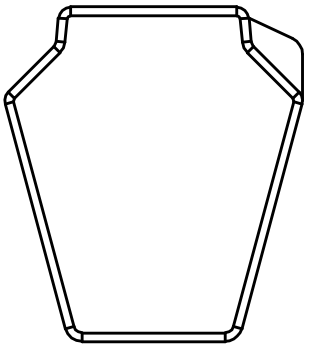
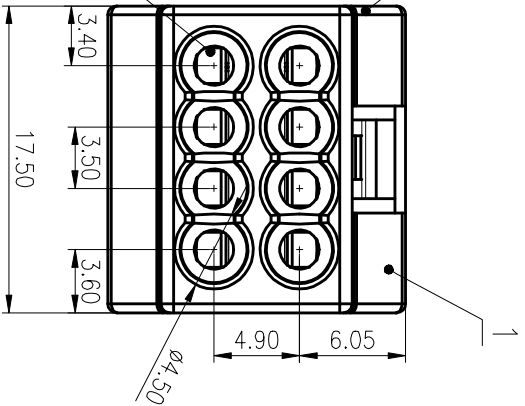
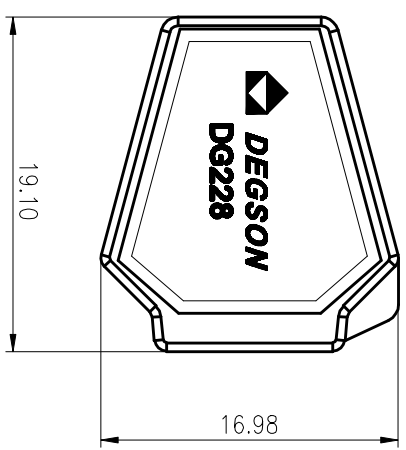
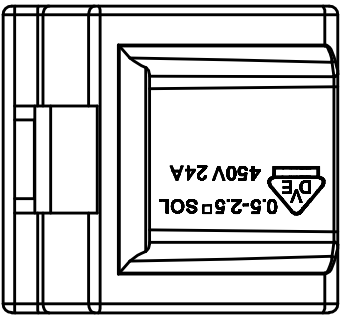

ITEM	NAME OF PART	MATERIAL	NOTES
3	Cover	PC	UL94V-2
2	Metals	Steel	Sn plated
1	Housing	PC	UL94V-2

UL 标准 /UL Standard:		B	C	D
额定电压/电涌/Rated Voltage(V)/Current(A)	600/15	/	/	/
IEC 标准 /IEC Standard:				
过压类别/Overvoltage Category/污染等级/Pollution Degree	III/3	III/2	II/2	
额定电压/电涌/Rated Voltage(V)/Current(A)	/	450/24	/	
工频耐压/Withstanding Voltage(V/Min)	/	AC2500	/	
绕线范围(硬线和软线)/Wire Range(rigid and flexible)(mm ² /AWG)	0.5~2.5/22~14			
间距/Pitch(mm)/绕线范围/Poles	3.5/08P			
铜线长度/Stripping length(mm)	10~13			
使用温度范围/Operating temperature(°C)	-40~+85			
符合RoHS环保要求/Conform to RoHS	Yes			

MATERIAL:		SURFACE: /	
MAT NO.:	/		
STATUS:	/		

NAME:	
APPD: LIGL	2020.06.03
CHKD: Mek	2020.06.03
DRAWING NO.:	DG228-3.5-08P-1Y-00A (H)

TYPE: CUSTOMER DRAWING		SCALE: 2.5:1 SHEET
DRAWING NO.:	DG228-3.5-C08	REV T2
DFT: LuoXM	2020.06.03	1/1

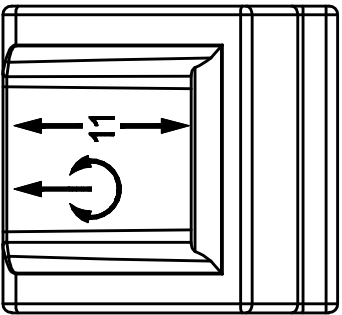

REV	ECN	DESCRIPTION	DFT	DATE
1				
2				
3				
4				
5				
6				

1 2 3 4 5 6