

The information provided herein is from CONNELY Electronic Co., Ltd. and is confidential. Any disclosure to a party other than the recipient is prohibited. The intellectual properties and its rights contained herein, including but not limited to, trademarks, patents, copyrights, trade secrets, and technical know-how, are owned exclusively by CONNELY or its affiliates. Unauthorized use or reproduction of any part of this document is strictly prohibited. CONNELY may enforce its intellectual property rights at its own discretion, failures or delays to exercise such rights does not constitute a waiver of such rights.

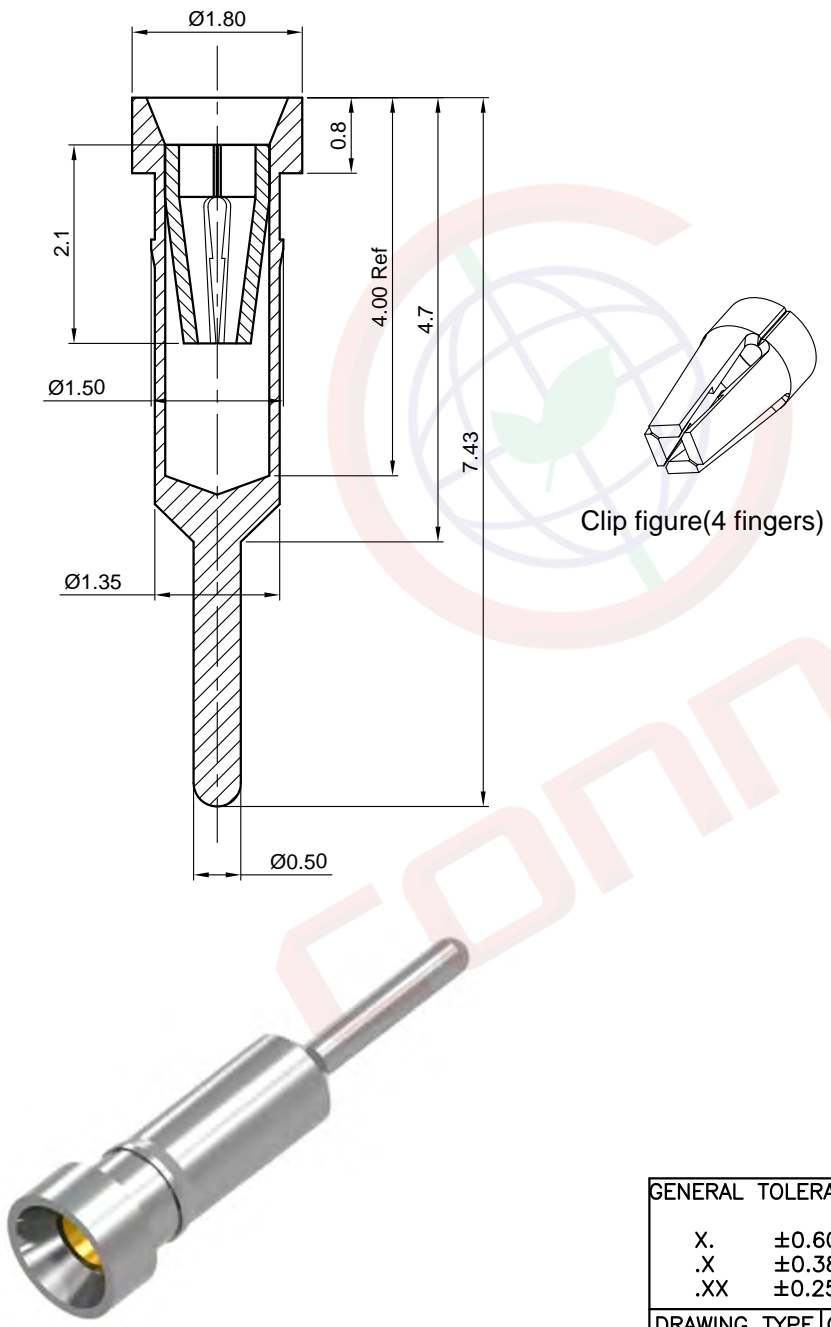

(Series Image-Reference Only)

REV.	DESCRIPTION	DRAWN	CHECKED	APPROVED
A	NEW RELEASE	HP 07/12/05'		LJC 07/12/05'
B	CHANGE THE DIM	YCH 08/17/13'		LJC 08/17/13'
C	DRAWING UPDATE	JLZ 07/17/18'		

Technical data

- Material**
 - . Pin(Outer Sleeve): Brass,Machined,CuZn38Pb2
 - . Clip: Copper alloy,Heat Treated
- Electrical**
 - . Current Rating: 3A max.
 - . Contact Resistance: 20mΩ max.
- Mechanical**
 - . *Average Insertion Force With Steel Pin of $\varnothing 0.43\text{mm}/0.017''$:
4-Finger 270g max
 - . *Average Withdrawal Force With Steel Pin of $\varnothing 0.50\text{mm}/0.020''$:
4-Finger 25g min
 - . *Mechanical Life: min 200 Cycles

4. Product number code:
DS1005-09 - X X X

- Clip plated
 - 6: Full Tin
 - 8: Full Gold flash
 - C: Full Gold 3u"
 - A: Full Gold 10u"
 - B: Full Gold 15u"
- Pin plated
 - 6: Full Tin
 - 8: Full Gold flash
 - C: Full Gold 3u"
 - A: Full Gold 10u"
 - B: Full Gold 15u"
- Clips
 - 4: 4Finger

GENERAL TOLERANCE		ANGLE TOLERANCE		PROJECTION		TITLE	
X.	±0.60	X.	±5°	UNITS	mm	SOCKET TERMINALS 7.43mm	
.X	±0.38	.X	±3°	SHEET SIZE	A4	SERIES	DS1005-09 SERIES
.XX	±0.25	.XX	±2°	晨翔电子有限公司 CONNFLY CONNELY ELECTRONIC CO. LTD			
DRAWING TYPE		CUSTOMER					
SCALE	1:1	SHEET	1 OF 1				
DRAWING NO.		C-DS1005-09-XXX-C					