

The information provided herein is from CONNELY Electronic Co., Ltd. and is confidential. Any disclosure to a party other than the recipient is prohibited. The intellectual properties and its rights contained herein, including but not limited to, trademarks, patents, copyrights, trade secrets, and technical know-how, are owned exclusively by CONNELY or its affiliates. Unauthorized use or reproduction of any part of this document for any purpose without the prior written permission of CONNELY may constitute a violation of such rights. CONNELY may enforce its intellectual property rights at its own discretion, failures or delays to exercise such rights does not constitute a waiver of such rights.

[Female]

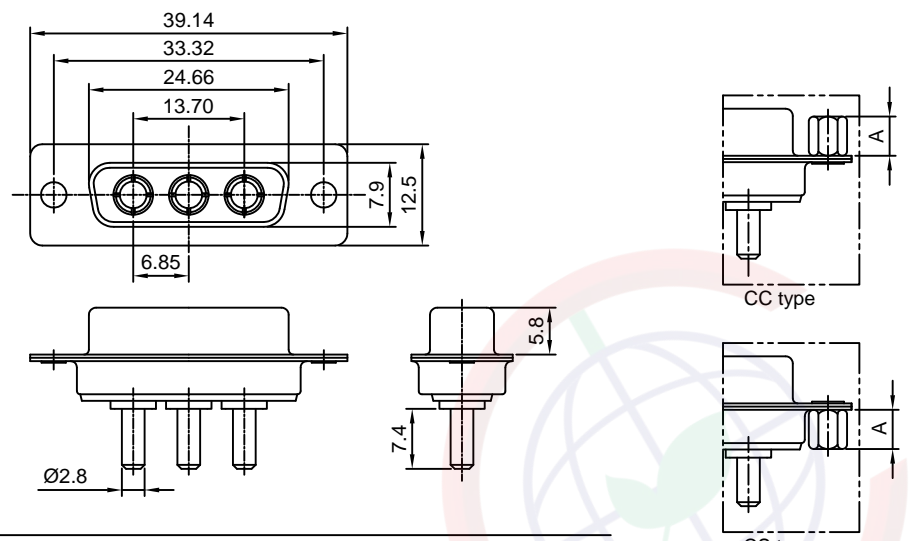

[Male]

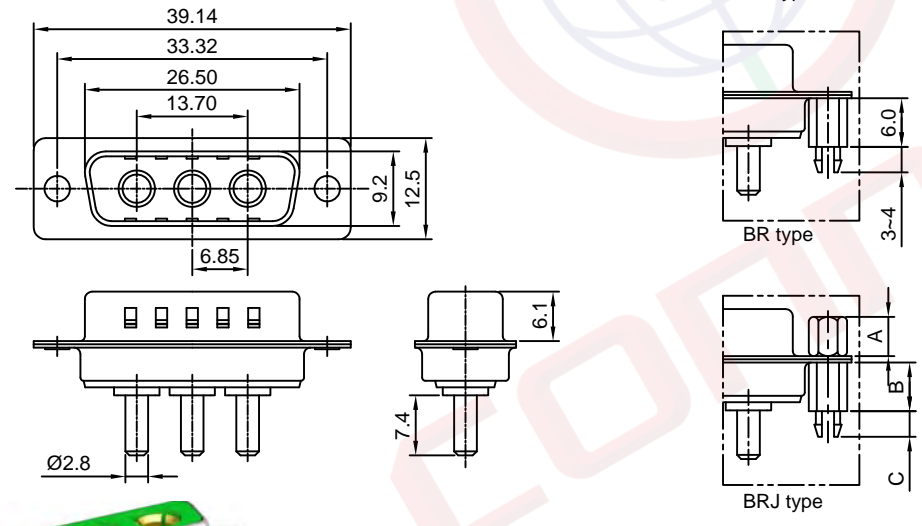

(Series Image-Reference Only)

REV.	DESCRIPTION	DRAWN	CHECKED	APPROVED
A	NEW RELEASE	LJC 01/17/09'		LJC 01/17/09'
B	DRAWING UPDATE	JLZ 09/08/20'		

Notes:

- Electrical characteristics:
 - Contact resistance: 20mΩ Max. Initial.
 - Dielectric withstanding voltage: 500V AC(rms)for 1 minute.
 - Insulation resistance: 1000MΩ Min.
 - Current rating: 40A
 - Voltage rating: 300V
- Environment characteristics:
 - Temperature range: -40° C ~ +105° C.
- Mechanical characteristics:
 - Durability: 500 cycles.
 - Contact retention force: 1Kgf Minimum.
- Materials:
 - Shell: SPCC.
 - Contact: Copper alloy.
 - Insulator: Thermoplastic UL 94V-0,Glass fiber filled.
- Part number code:

DS1034-19- X X X X X X

- Screw Dim. A
- S: Standard(W/O nut)
- 4: 4.80
- 5: 5.80
- Screw type
- S: Standard(W/O nut)
- 1: CC type
- 2: CS type
- 3: BR type
- 4: BRJ type Dim. B:6.00 C: 3~4mm
- 5: BRJ type Dim. B:6.00 C: 5~6mm
- Contact plating
- 8: Full gold flash
- Shell plating
- N: Fornt shell nickel,Back shell tin
- Housing color
- B: Black
- Connector type
- M: Male
- F: Female

GENERAL TOLERANCE		ANGLE TOLERANCE	
X.	±0.60	X.	±5°
.X	±0.38	.X	±3°
.XX	±0.25	.XX	±2°

DRAWING TYPE	CUSTOMER		
SCALE	1:1	SHEET	1 OF 1
DRAWING NO.	C-DS1034-19-XXXXXX-B		

PROJECTION	TITLE	MACHINE PIN D-SUB 3P
UNITS	mm	V/T TYPE
SHEET SIZE	A4	SERIES DS1034-19 SERIES

晨翔电子有限公司
CONNFLY ELECTRONIC CO. LTD