

|      |   |
|------|---|
| Dept |   |
| Qty  |   |
| DC   | 1 |
| ED   | 1 |
| IE   | 1 |
| ISO  | 1 |
| PD   | 1 |
| R&D  | 1 |
| SD   | 1 |
| QA   | 1 |
| QC   | 1 |
| QE   | 1 |

The information provided herein is from CONNELY Electronic Co., Ltd. and is confidential. Any disclosure to a party other than the recipient is prohibited. The intellectual properties and its rights contained herein, including but not limited to, trademarks, patents, copyrights, trade secrets, and technical know-how, are owned exclusively by CONNELY or its affiliates. Unauthorized use or modification is strictly prohibited. CONNELY may enforce its intellectual property rights at its own discretion, failure or delays to exercise such rights does not constitute a waiver of such rights.

| REV. | DESCRIPTION    | DRAWN         | CHECKED       | APPROVED      |
|------|----------------|---------------|---------------|---------------|
| A    | NEW RELEASE    | JLZ 07/27/18' | HZW 07/27/18' | LJC 07/27/18' |
| B    | DRAWING UPDATE | JLZ 06/19/19' |               |               |
|      |                |               |               |               |
|      |                |               |               |               |

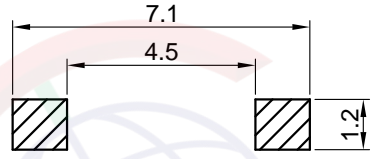
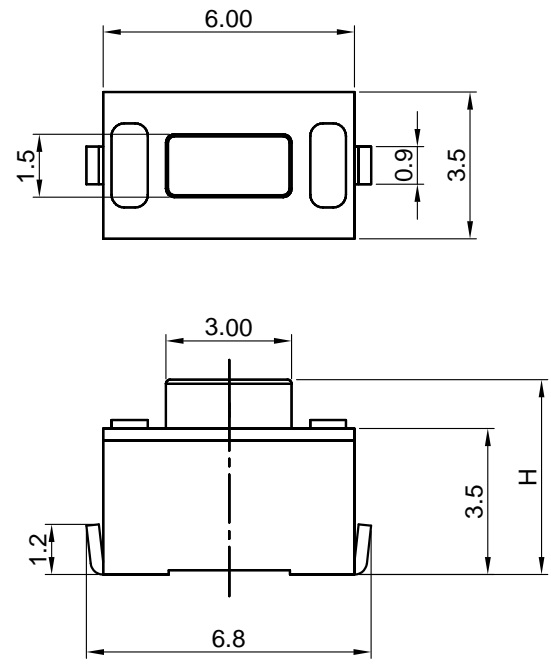

Recommend PCB layout  
Tolerance:±0.05

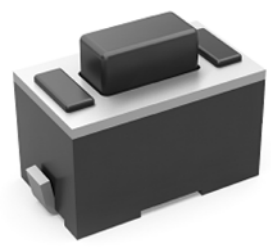
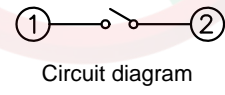

(Series Image-Reference Only)

NOTES:

- Specifications:
  - Contact Rating: 50mA at 12V DC
  - Insulation Resistance: 100MΩ min.
  - Contact Resistance: 50mΩ max.
  - Dielectric Withstanding Voltage: 250V AC(rms) for 1 minute.
  - Operating Life: 30,000 cycles
  - Travel: 0.25±0.1mm
  - Operation Temperature Range: -25°C to +70°C
  - Wave Soldering: Recommended Solder Temperature at 500°F(260°C)max. 5 Seconds
  - Hand Soldering: Use Soldering Iron Of 30 Watts, Controlled at 608°F(320°C) Approximately 2 Seconds.
- Product number code:

DS1042-23 - X X X X X X X

- X Operating Life
  - 03: 30,000 cycles
  - 05: 50,000 cycles
- X Operating force
  - 160: 160±30gf
  - 250: 250±30gf
- X Packing type
  - A: polybag
  - B: tube
  - R: tape & reel
- X Actuator color
  - B: Black
  - E: Orange
  - N: Brown
- X Housing color
  - B: Black
- X Profile Height(DIM. H)
  - 043: 4.3mm
  - 050: 5.0mm
- X No. of contacts
  - 2: 2P

|                   |       |                     |        |  |    |                                  |                  |
|-------------------|-------|---------------------|--------|--|----|----------------------------------|------------------|
| GENERAL TOLERANCE |       | ANGLE TOLERANCE     |        | PROJECTION                                     |    | TITLE                            |                  |
| X.                | ±0.60 | X.                  | ±5°    | UNITS  | mm | TACT SWITCH SMT TYPE 3.5mmX6.0mm |                  |
| .X                | ±0.38 | .X                  | ±3°    | SHEET SIZE                                     | A4 | SERIES                           | DS1042-23 SERIES |
| .XX               | ±0.25 | .XX                 | ±2°    | 晨翔电子有限公司<br>CONNELY CONNELY ELECTRONIC CO. LTD |    |                                  |                  |
| DRAWING TYPE      |       | CUSTOMER            |        |  |    |                                  |                  |
| SCALE             | 1:1   | SHEET               | 1 OF 1 |  |    |                                  |                  |
| DRAWING NO.       |       | C-DS1042-23-XXXXX-B |        |  |    |                                  |                  |