

The information provided herein is from CONNELY Electronic Co., Ltd. and is confidential. Any disclosure to a party other than the recipient is prohibited. The intellectual properties and its rights contained herein, including but not limited to, trademarks, patents, copyrights, trade secrets, and technical know-how, are owned exclusively by CONNELY or its affiliates. Unauthorized use of this information in any format or manner. CONNELY may enforce its intellectual property rights at its own discretion; failures or delays to exercise such rights does not constitute a waiver of such rights.

1                      2                      3                      4                      5                      6                      7                      8

REV.	DESCRIPTION	DRAWN	CHECKED	APPROVED
A	NEW RELEASE	LL 11/13/06'		LJC 11/13/06'
B	DRAWING UPDATE	JLZ 08/26/19'		

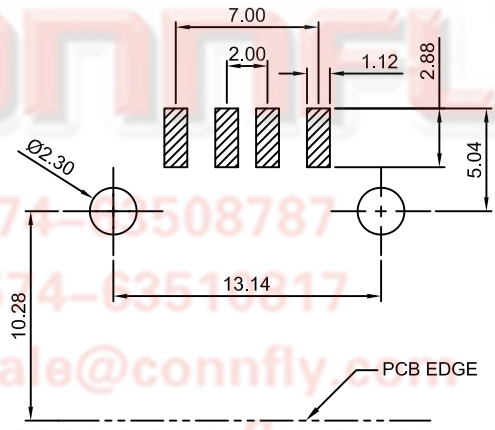
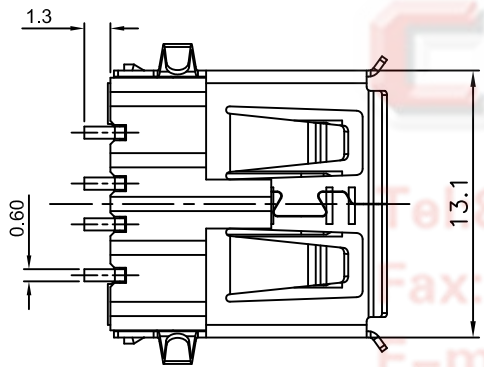
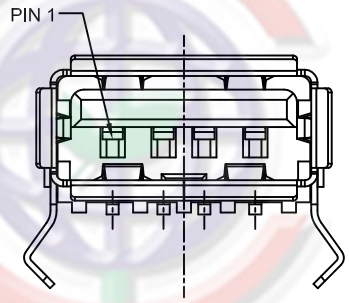
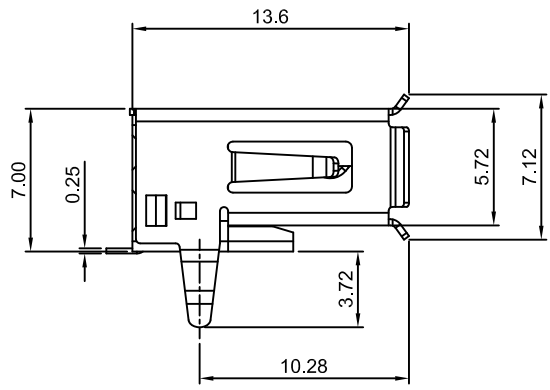

RECOMMEND PCB LAYOUT  
(TOLERANCE=±0.05)

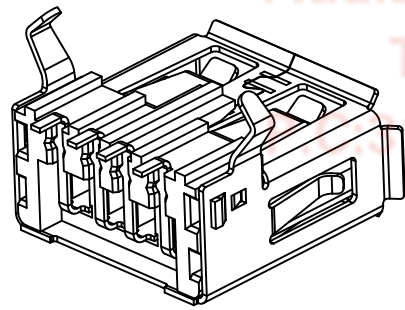

- Notes:  
Specifications:
- Contact Resistance: 30mΩ Max.
  - Insulation Resistance: 1000MΩ Min.
  - Dielectric Withstanding Voltage: 750V AC(rms) For 1 Minute.
  - Current Rating: 1.5A Max
  - Voltage Rating: 30V Max
  - Temperature: -40°C~+85°C.
- Materials:
- Contact Material: Copper Alloy.
  - Shell Material: Copper Alloy or Steel.
  - Insulator Material: High temp, UL94-V0.
- Mechanical Characteristics:
- Mating Force: 3.57Kgf Maximum.
  - Unmating Force: 1.02Kgf Minimum.
  - Durability: 1500 Cycles
- Product Number Code:

DS1095 - X X X X - X

- Shell material
- Fe: Steel
- N/A Code: Copper alloy
- Contact plating
- 0: Selective gold flash
- 03: Selective gold 3u"
- 30: Selective gold 30u"
- Mounting type
- M: SMT
- Shell plating
- N: Nickel
- 6: Tin
- Color of housing
- W: White
- B: Black

GENERAL TOLERANCE		ANGLE TOLERANCE	
X.	±0.60	X.	±5°
.X	±0.38	.X	±3°
.XX	±0.25	.XX	±2°

DRAWING TYPE	CUSTOMER		
SCALE	1:1	SHEET	1 OF 1
DRAWING NO.	C-DS1095-XXMX-B		

PROJECTION		TITLE	USB Female A Type SMT series	
UNITS	mm	SHEET	A4	
SHEET SIZE	A4	SERIES	DS1095 SERIES	

晨翔电子有限公司  
CONNFLY CONNELY ELECTRONIC CO. LTD

1                      2                      3                      4                      5                      6                      7                      8