

REV.	DESCRIPTION	DRAWN	CHECKED	APPROVED
A	NEW RELEASE	JLZ 03/27/17'		

SPECIFICATION

- Insulation Resistance:1000MΩ Min.
- Withstand Voltage:500V AC/Minute.
- Durability:600 Mating Cycles Min.
- Product Number Code:

DS1134-13-X X X X X X  
 L Ear Support  
 S:W/ Ear  
 Housing Materials  
 P:PBT  
 Contact Plating  
 0:Selective gold flash  
 3:3u" Gold  
 6:6u" Gold  
 15:15u" Gold  
 30:30u" Gold  
 Housing Color  
 B:Black  
 No.Of Contacts  
 8:8P8C  
 Connector Type  
 S:Socket  
 Series No.  
 DS1134-13

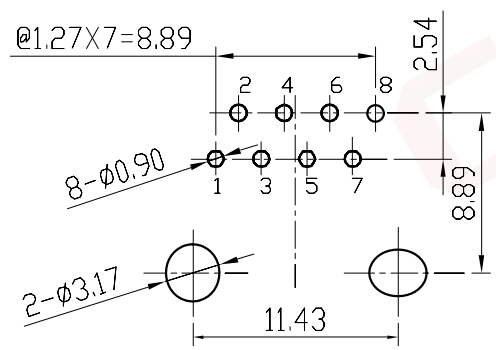
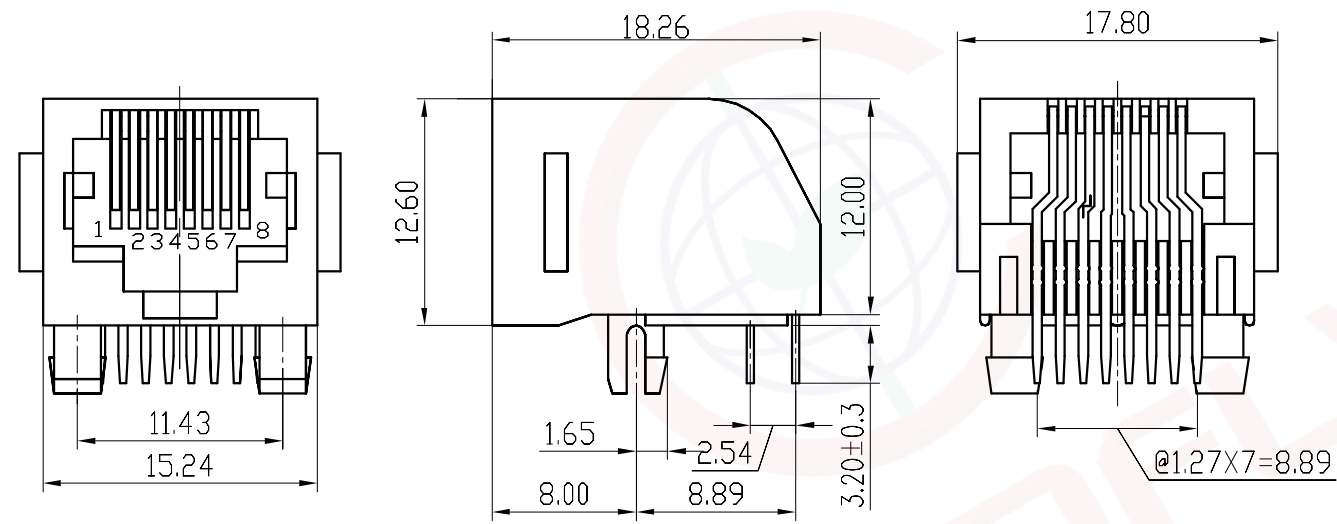

GENERAL TOLERANCE		ANGLE TOLERANCE		PROJECTION		TITLE	PCB JACK 8P	
X.	±0.60	X.	±5°	UNITS	mm			
.X	±0.38	.X	±3°	SHEET SIZE	A4	SERIES	DS1134-13 SERIES	
.XX	±0.25	.XX	±2°	<b>晨翔电子有限公司</b> <b>CONNFLY CONNFLY ELECTRONIC CO. LTD</b>				
DRAWING TYPE		CUSTOMER						
SCALE		1:1	SHEET 1 OF 1					
DRAWING NO.		C-DS1134-13-XXXXXX-A						