

Dept	
Qty	
DC	1
ED	1
IE	1
ISO	1
PD	1
R&D	1
SD	1
QA	1
QC	1
QE	1

The information provided herein is from CONNELY Electronic Co., Ltd. and is confidential. Any disclosure to a party other than the recipient is prohibited. The intellectual properties and its rights contained herein, including but not limited to, trademarks, patents, copyrights, trade secrets, and technical know-how, are owned exclusively by CONNELY or its affiliates. Unauthorized use of this information in any format or manner. CONNELY may enforce its intellectual property rights at its own discretion; failures or delays to exercise such rights does not constitute a waiver of such rights.

REV.	DESCRIPTION	DRAWN	CHECKED	APPROVED
A	NEW RELEASE	JLZ 07/13/18'		

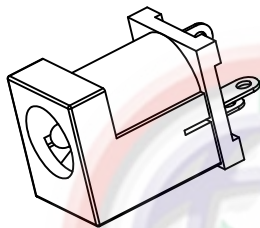

- NOTES:
- ELECTRICAL CHARACTERISTICS:
 - CONTACT RESISTANCE: 30mΩ Max.
 - DIELECTRIC WITHSTANDING VOLTAGE: 250V AC(rms) FOR 1 MINUTE.
 - INSULATION RESISTANCE: 100MΩ Min.
 - CURRENT RATING:3A.
 - ENVIRONMENT CHARACTERISTICS:
 - TEMPERATURE: -25°C~+70°C.
 - MATERIALS
 - CONTACT MATERIAL: COPPER ALLOY.
 - CONTACT PLATING: Ag
 - INSULATOR MATERIALS: NYLON,BLACK.
 - PRODUCT NUMBER CODE:

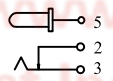
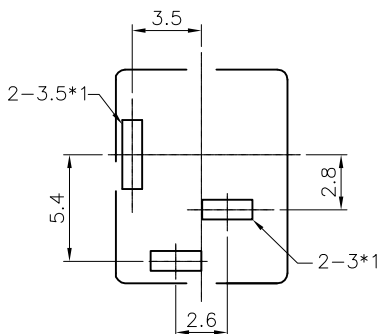
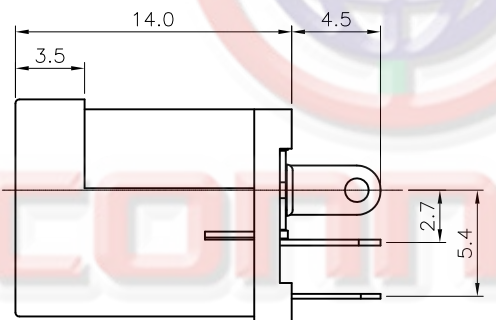
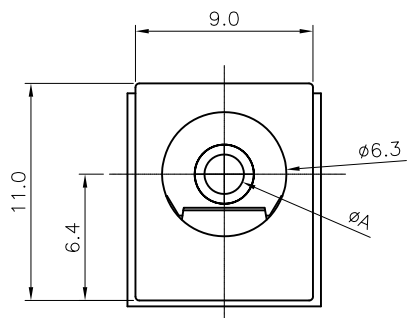

CIRCUIT DIAGRAM

DS1152-07 - X X X X X 0 X X

- Pin Dim. A type
 - 0: A=1.65mm
 - 1: A=2.0mm
 - 2: A=2.35mm
 - 3: A=2.5mm
- Packing type
 - P: Ploybag
- Housing color
 - B: Black
- Contact Plating
 - Y: Full Silver
- Mounting type
 - V: V/T type
- Connector type
 - S: Socket
- No.OF CONTACTS
 - 03

Tel:86-574-63508787
 Fax:86-574-63510817
 E-mail:sale@connfly.com
 http://www.connfly.com
 Add:East Industry Zone KuangYan
 Town Cixi Ningbo China
 P.C:315333

GENERAL TOLERANCE		ANGLE TOLERANCE		PROJECTION		TITLE	ø6.3mm DC Power Jack V/T Type	
X.	±0.60	X.	±5°	UNITS	mm			
.X	±0.38	.X	±3°	SHEET SIZE	A4	SERIES	DS1152-07 SERIES	
.XX	±0.25	.XX	±2°	晨翔电子有限公司 CONNFLY CONNELY ELECTRONIC CO. LTD				
DRAWING TYPE		CUSTOMER						
SCALE		1:1	SHEET 1 OF 1					
DRAWING NO.		C-DS1152-07-XXXXX0XX-A						